

CURVED X-STREAM™ AIR BLADE™ AIR KNIFE

New Fan Blowoff Continues the Gold Standard in Air Knife Curtain Blowoff Technology

The new X-Stream™ Curved Air Blade™ Air Knife is easy to mount and maintain. It reduces both compressed air consumption and noise levels. It's curved design produces an expanding, powerful blast of air in a fan shape to blowoff wide areas and can minimize air use using longer Air Knives.

Developed to address areas with limited space to blowoff a large area.

As with regular X-Stream™ Air Blade™ Air Knives, the X-Stream™ Curved Air Blade™ Air Knife produces a "laminar" flow of air along its curved face using the "Coanda" effect which entrains a large volume of air from the surrounding area along with a small amount of compressed air to produce an output flow up to 40 times.

FEATURES:

Curved X-Stream™ Air Blade™ Air Knife is a full flow design with top or bottom mounting holes to easily attach to equipment. Rear air inlet port for compressed air. It is anodized for longer life.

- ▶ Made of anodized aluminum for long life
- ▶ Air inlet port on the back for a compact design and minimal air interference
- ▶ Airflow amplification of approximately 40:1 compared to 3:1 for drilled pipe or open jets and tubes
- ▶ Instant on-off with no moving parts, no electricity or explosion hazard

Inlet Pressure	Air Consumption SCFM per in. (SLPM per 25 mm) with standard .002"(.05 mm) gap	Air Consumption SCFM per in. (SLPM per 25 mm) with .004" (.10 mm) gap (shim added)
20 PSIG (1.4 BAR)	9.5 (269)	18.9 (535)
40 PSIG (2.8 BAR)	13.3 (377)	26.7 (756)
60 PSIG (4.1 BAR)	18.1 (513)	36.2 (1025)
80 PSIG (5.5 BAR)	22.0 (623)	44.0 (1246)
100 PSIG (6.9 BAR)	25.9 (734)	51.8 (1467)
120 PSIG (8.4 BAR)	30.6 (867)	61.2 (1733)

PART NO.	DESCRIPTION
19005X	Aluminium Curved X-Stream™ Air Blade™ Air Knife - 5" Radius
19105XS	Aluminium Curved X-Stream™ Air Blade™ Air Knife Stainless Steel Shim -5" Radius

(* BSP Threads or Adaptors can be supplied depending on country location)



BENEFITS:

- ▶ Built and designed for significantly longer life in difficult environments than many competing products.
- ▶ Easy to fit in small spaces.
- ▶ Energy reduction in compressed air use up to 90% and noise reductions of 15 dBA.
- ▶ Maintenance free with output easily controlled, safe to use.

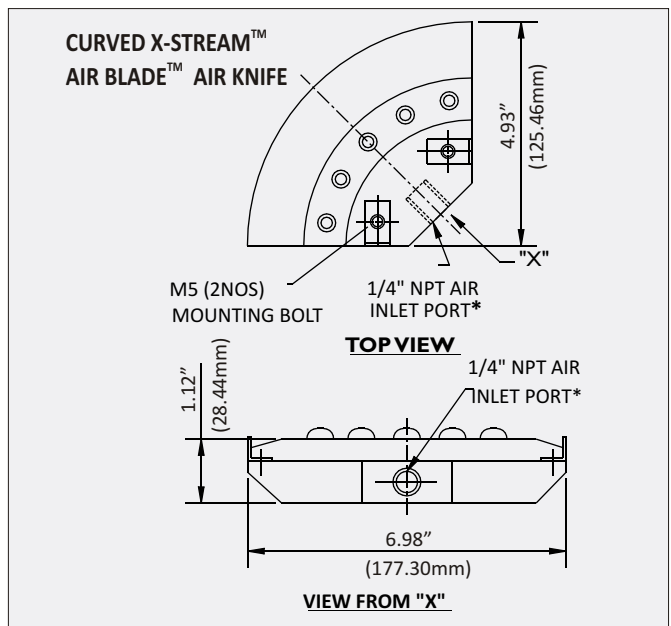

AIR BLADE™ AIR KNIFE

