

Leading Technology Into The Future

NEX FLOW™

Technologies Inc.

MACHINE TOOL COOLING SYSTEM ALL METAL, STAINLESS STEEL, QUIET

MACHINE TOOL COOLING SYSTEM

Frigid-X Cold Air Machine Tool Cooling System for dry machining applications - replaces polluting and often toxic mist systems to improve dry machining operations. No mess, no residue and low in cost.

Efficient Nex-Flow™ Frigid-X™ Machine Tool Cooling System can improve dry machining operations and assist in spot cooling applications for a variety of industrial machining processes but increasing machining rates and extending tool life.

The Nex-Flow™ Frigid-X™ Machine Tool Cooling System produces cold air at approximately 50° F (28° C) below supply air temperature. The unit is muffled for quiet operation. No moving parts assures long life, maintenance free operation while extending tool life and improving production rates.

Frigid-X™ Machine Tool Cooling Systems can often replace costly mist coolants and certainly improves the quality and output of all types of dry machining operations from metals to plastics. Unit is low cost, no electricity with no moving parts and is essentially maintenance free.

Applications

- Tool sharpening
- Grinding
- Milling
- Drilling
- Band sawing
- Plastic machining
- Routing & Chill Roll Cooling



Operation

The Frigid-X™ Machine Tool Cooling System uses a vortex tube to produce cold air at one end. Hot air is exhausted as waste at the muffled hot end. The cold air is also muffled and exists through the flexible hose, which is used to direct the air to the spot where cooling is required. A magnetic base allows for portability and easy mount of the unit to the machine.

**E-Mail: sales@nexflowair.com
Web Site: www.nexflowair.com**

Leading Technology Into The Future
NEX FLOW™
Technologies Inc.

MACHINE TOOL COOLING SYSTEM

USING THE FRIGID-X™ MACHINE TOOL COOLING SYSTEM

Always use clean, dry compressed air. A manual filter is supplied with every system to insure dry air. If oil is a major problem in the compressed air line, an oil removal filter is also recommended. The temperature of the air can be controlled by reducing the pressure using either a regulator or manual shut-off valve. A solenoid valve may also be connected into the machine operation to turn the air supply to the cooling unit on-off as it is needed, thereby conserving compressed air usage.

SELECTING THE RIGHT MODEL

Nex-Flow™ FRIGID-X™ Air Coolant Systems are available with either a single point or dual point hose kit. The single point system is used for most drilling and grinding operations where point cooling is required. Milling, band sawing or other operations where the heat is generated over a larger surface area, require a dual point outlet to cover the larger area. To convert a single point system to a dual point simply purchase the dual point hose kit.

DIMENSIONS

FRIGID-X TOOL COOLING SYSTEM - Model 56015FS

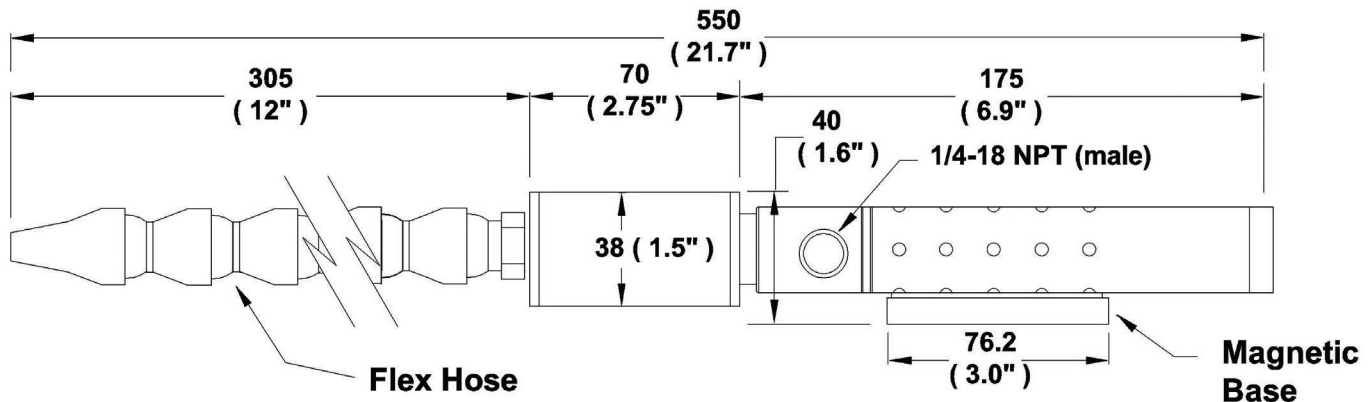

Wow! This really is the best NEX thing.
Quality at a decent price!

Leading Technology Into The Future
NEX FLOW™
Technologies Inc.

INTERNATIONAL
Tel: (416) 410-1313
Fax: (416) 410-1806

USA & CANADA
Tel: (877) 797-2777
Fax: (877) 797-2660

INTERNET
www.nexflowair.com
sales@nexflowair.com